

**Features**

- On Chip Hall Sensor
- Rotor-Locked Shutdown
- Automatically Restart
- Frequency Generator (FG) Output
- Built-in Zener Protection for Output Driver
- Operating Voltage: 1.8V~5.75 V
- Output Current:  $I_{O(AVE)} = 400 \text{ mA}$
- Lead Free Finish/RoHS Compliant for Lead Free products (Note 1)
- Lead Free Packages: SOT89-5L

**General Description**

AH292 is a monolithic fan motor controller with Hall sensor's capability. It contains two complementary open-collector transistors for motor's coil driving, automatic lock current shutdown, and recovery protections. In addition a Frequency generator (FG) output is also available for speed detection.

Rotor-lock shutdown detection circuit turns off the output driver when the rotor is blocked to avoid coil overheat. Then, the automatic recovery circuit will restart the motor. These protected actions are repeated and periodic during the blocked period. Until the blocking is removed, the motor recovers and runs normally.

**Ordering Information**

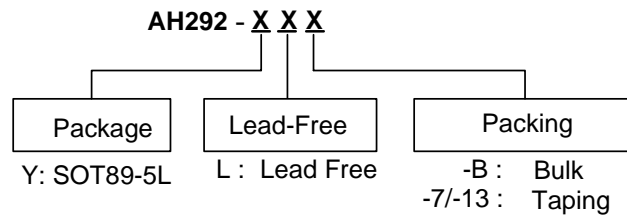

Note: 1. RoHS revision 13.2.2003. Glass and High Temperature Solder Exemptions Applied, see *EU Directive Annex Notes 5 and 7*.

Device	Package Code	Packaging (Note 2)	Tube/Bulk		7" Tape and Reel	
			Quantity	Part Number Suffix	Quantity	Part Number Suffix
AH292-Y	Y	SOT89-5L	NA	NA	2500/Tape & Reel	-13

Note: 2. Pad layout as shown on Diodes Inc. suggested pad layout document AP02001, which can be found on our website at <http://www.diodes.com/datasheets/ap02001.pdf>.

**Pin Assignment**

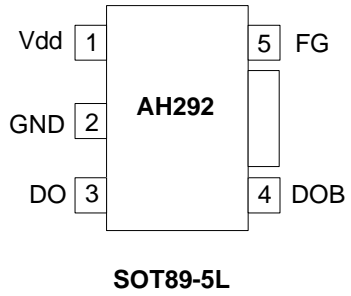

**Pin Descriptions**

Symbol	Description
FG	Frequency Generation
V <sub>dd</sub>	Input Power
DO	Output Pin
DOB	Output Pin
GND	Ground

**Block Diagram**

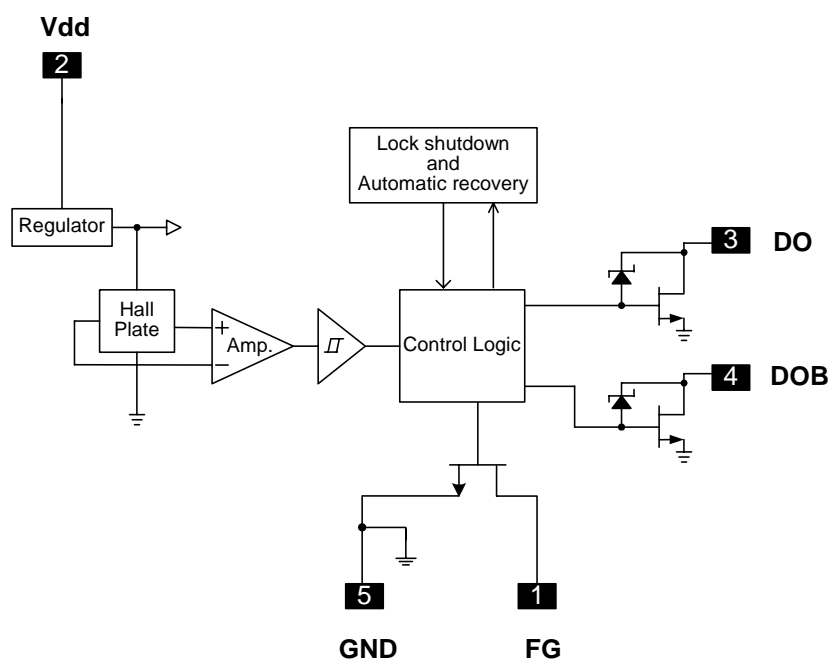

**Typical Application Circuit**

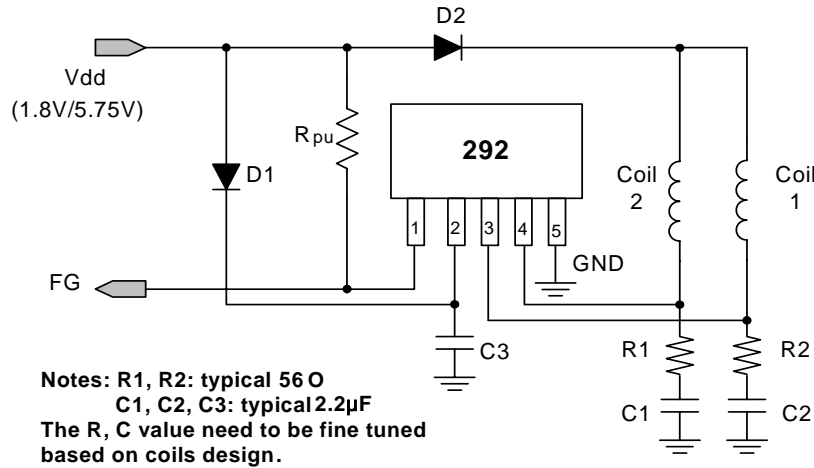

**1.8V/5.75V DC Brush-less Fan with FG output function**

**Absolute Maximum Ratings** (TA = 25°C)

Characteristics	Symbol	Rating	Unit
Operating Supply Voltage	V <sub>dd</sub>	8	V
Output Current	I <sub>O(AVE)</sub>	400	mA
	I <sub>O(PEAK)</sub>	700	
Power Dissipation	P <sub>D</sub>	800	mW
Operating Temperature	T <sub>opr</sub>	-20 ~ 100	°C
Storage Temperature	T <sub>stg</sub>	-55 ~ 150	°C
Maximum Junction Temperature	T <sub>j</sub>	150	°C

**Electrical Characteristics** (  $T_A = 25\text{ }^\circ\text{C}$ ,  $V_{dd} = 5\text{V}$ , unless otherwise specified )

Characteristics	Symbol	Conditions	Min.	Typ.	Max.	Unit
Supply Voltage	$V_{dd}$	Operating	1.8*	-	5.75	V
Supply current	$I_{dd}$	Operating	-	2.6	4.0	mA
Locked Protection On	$T_{lrp-on}$		-	0.4	-	Sec
Locked Protection Off	$T_{lrp-off}$		2.4	3	3.6	Sec
Output saturation voltage	$V_{OUT(SAT)}$	$I_o = 180\text{mA}$	-	300	-	mV
		$I_o = 350\text{mA}$	-	600	-	
Output On Resistance	$R_{ds(on)}$		-	1.75	-	ohm
FG output Vds	$V_{ol}$	$I_o = 10\text{mA}$	-	0.5	-	V
Output Zener-breakdown Voltage	$V_z$		-	15	-	V

\*Note: The output of IC will be switched after the supply voltage is over 1.8V, but the magnetic characteristics won't be normal until the supply is over 2.0V.

**Truth Table**

IN-	IN+	CT	OUT1	OUT2	FG	Mode
H	L	L	H	L	H	Rotating
L	H	L	L	H	L	Rotating
-	-	H	off	off	-	Lockup protection activated

**Magnetic Characteristics** (  $T_A = 25\text{ }^\circ\text{C}$ ,  $V_{dd} = 5\text{V}$ , unless otherwise specified )

( 1mT = 10 Gauss )

Characteristics	Symbol	Min.	Typ.	Max.	Unit
Operation Point	Bop	--	30	60	Gauss
Release Point	Brp	-60	-30	--	Gauss
Hysteresis	Bhy	--	60	--	Gauss

**Operating Characteristics**

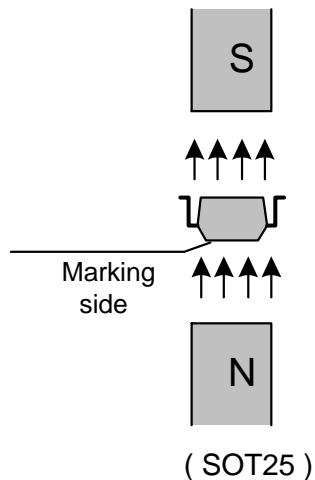
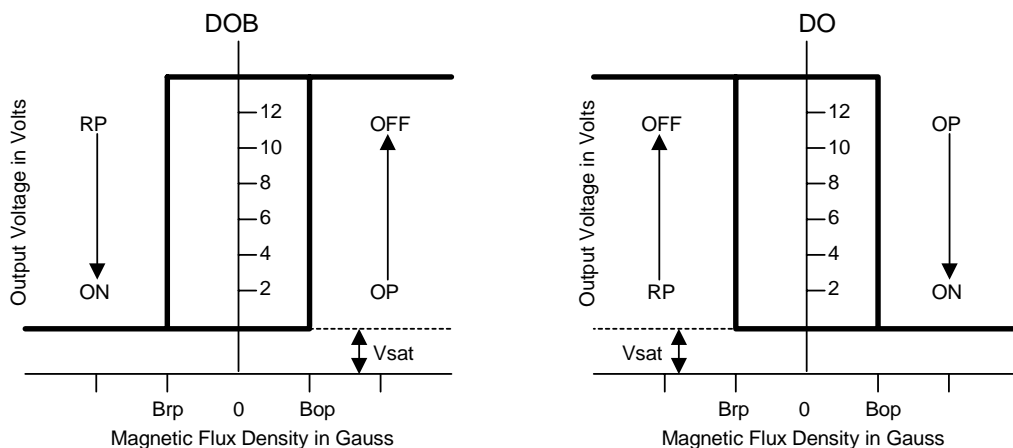

**Performance Characteristics**

(1) SOT89-5L

TA (°C)	25	50	60	70	75	80	85	90	95	100
PD (mW)	800	640	576	512	480	448	416	384	352	320
TA (°C)	105	110	115	120	125	130	135	140	145	150
PD (mW)	288	256	224	192	160	128	96	64	32	0

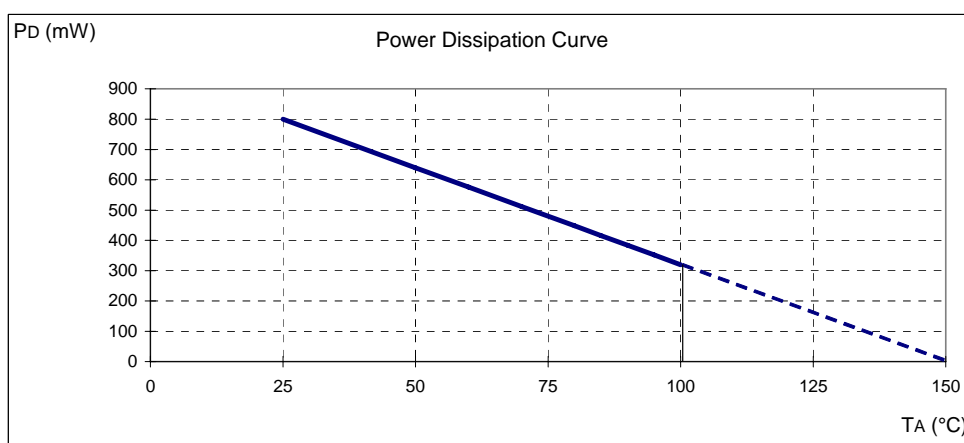

**Marking Information**

(1) SOT89-5L

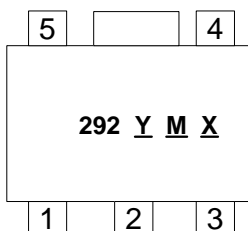

Y : Year: 0-9

M : Month: A~L

X : Internal code

a~z : Lead Free

**Package Information** (unit: mm)

**(1) Package type: SOT89-5L**

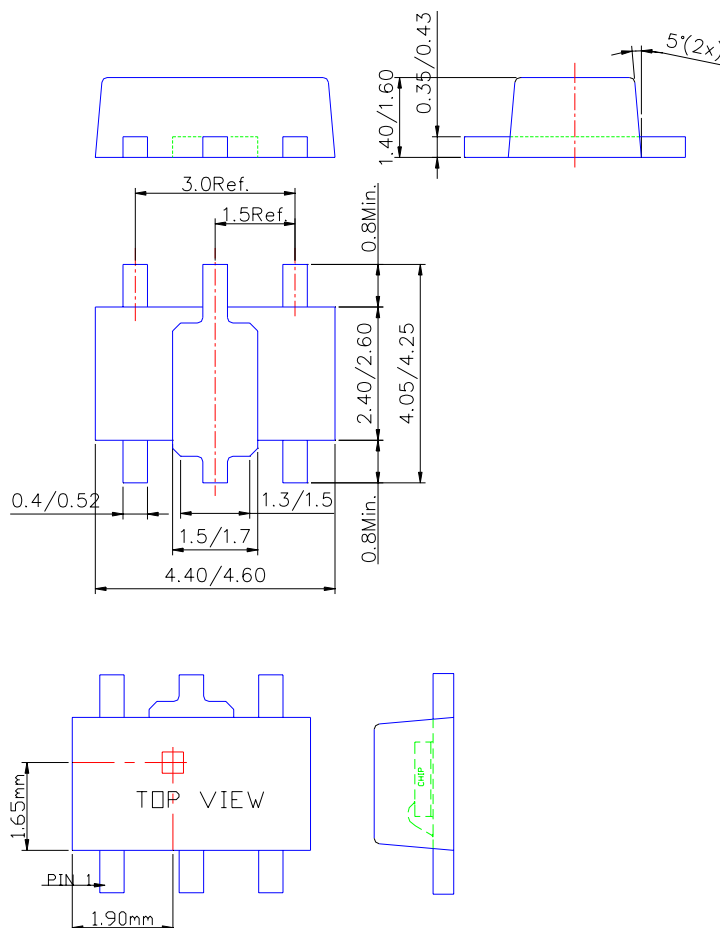

**Sensor Location**

**IMPORTANT NOTICE**

Diodes Incorporated and its subsidiaries reserve the right to make modifications, enhancements, improvements, corrections or other changes without further notice to any product herein. Diodes Incorporated does not assume any liability arising out of the application or use of any product described herein; neither does it convey any license under its patent rights, nor the rights of others. The user of products in such applications shall assume all risks of such use and will agree to hold Diodes Incorporated and all the companies whose products are represented on our website, harmless against all damages.

**LIFE SUPPORT**

Diodes Incorporated products are not authorized for use as critical components in life support devices or systems without the expressed written approval of the President of Diodes Incorporated.